

SKM42A3729T-C is a high quality, low cost, low power analog output front pick-up tone omnidirectional MEMS microphone. The SKM42A3729T-C consists of a MEMS microphone element and a preamplifier. SKM42A3729T-C has a high SNR and flat broadband frequency response, so that it has a high definition of natural voice. As built in filter, SKM42A3729T-C adopts LGA metal case surface mount package. This makes reflow soldering compatibility less sensitive. SKM42A3729T-C is halogen free product.

Feature:

- 3.76mm x 2.95mm x 1.1mm package specifications
- Signal-to-noise ratio 58dBA
- Sensitivity is -42dBV
- Low consumption current <180 μ A

Application:

- Mobile phone
- Handheld computer
- Digital video camera
- Portable media equipment with audio input

Typical application:

The SKM42A3729T-C output can be connected to the CODEC microphone input or a high input impedance gain stage. The output of the microphone must be connected to the capacitance (obstructing DC).

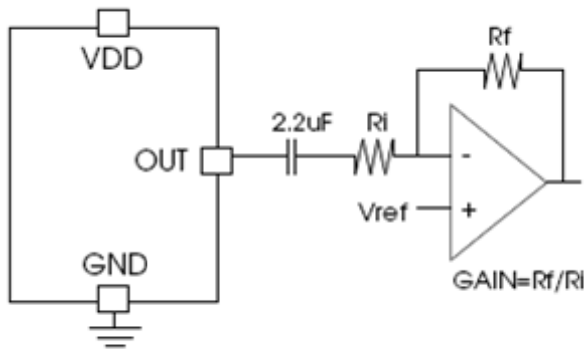

Connect to Audio OPAMP

Pin configuration and description

Button view

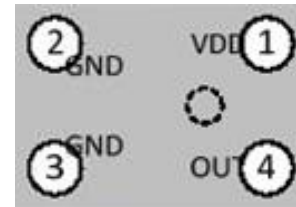

PIN	Symbol	Description
4	OUT	Output signal
2,3	GND	GND
1	VDD	VDD

Absolute maximum rating:

- The power supply voltage: -0.5V to +4V
- The sound pressure level: 160dB
- Mechanical shock: 10000g
- Shake: Follow MIL-STD-883 Method
- The range of temperature: -40 $^{\circ}$ C to +125 $^{\circ}$ C

Note: the above stresses that "absolute maximum ratings" may cause permanent damage to the device. The sound pressure level and operation on these or any other equipment are not absolute.

ESD sensitivity



The integrated circuit can be used through ESD. It is suggested that all integrated circuits should take appropriate precautions. Erroneous observation or improper handling of installation procedures can cause damage. The range of ESD damage can be reduced from subtle performance to equipment failure.

Schematic diagram :

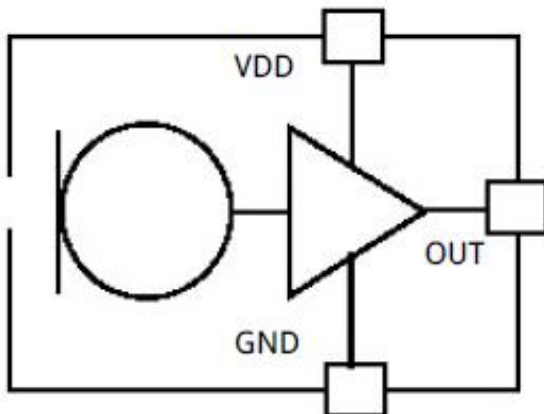

Characteristic (TA =25°C, VDD = +1.8V, Unless otherwise stated)

Parameter	Symbol	Test condition	Min	TYP	Max	Unit
Directivity				Omnibeare -ing		
Power voltage	VDD		1.5		3.6	V
Power current	IDD		80	120	180	μA
Sensitivity (accurate to ± 1dB)		1kHz,94dB SPL	-45	-42	-39	dBV
Signal to noise ratio	SNR			58		dB
Equivalent output noise	EIN			36		dBA SPL
Total harmonic distortion	THD	105dB SPL			3	%
Sound source rejection ratio	PSRR	217Hz,100mV Vp-p,square wave on VDD		-55		dB
Maximum output sound				120		dB SPL
Output impedance	Zout			150	300	Ω
Output DC offset				0.75		V
Output current limit				90		μA
Polarity				The same		

Reliability index

According customer requirements. Microphone sensitivity can be change to ± 1dB or ± 3db.

Test item	Description
THT	+65°C/85% humidity, 500h
Temperature cycle	-40°C/+125°C, 100 cycles.
High temperature storage	+150°C, 500h.
Cryogenic storage	-40°C, 500h.
Electrostatic discharge	3 discharges at +/-8kV direct contact to the lid when unit is grounded (IEC 61000-4-2) and 3 discharges at +/-2kV direct contact to the I/O pins (MIL 883E, Method 3015.7).

Frequency Response :

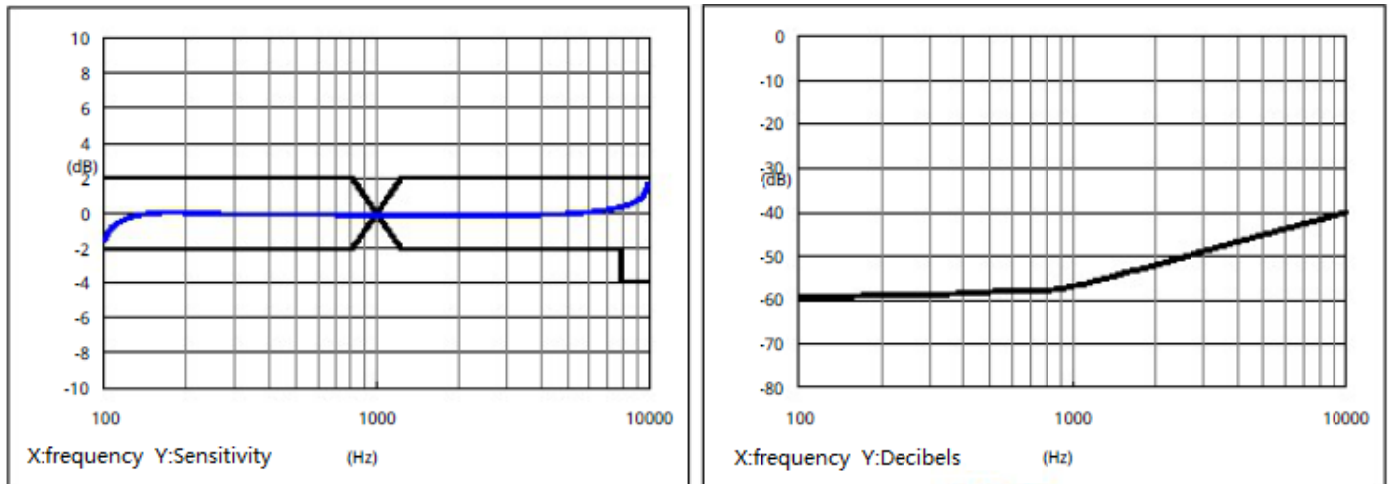

Dimension parameter

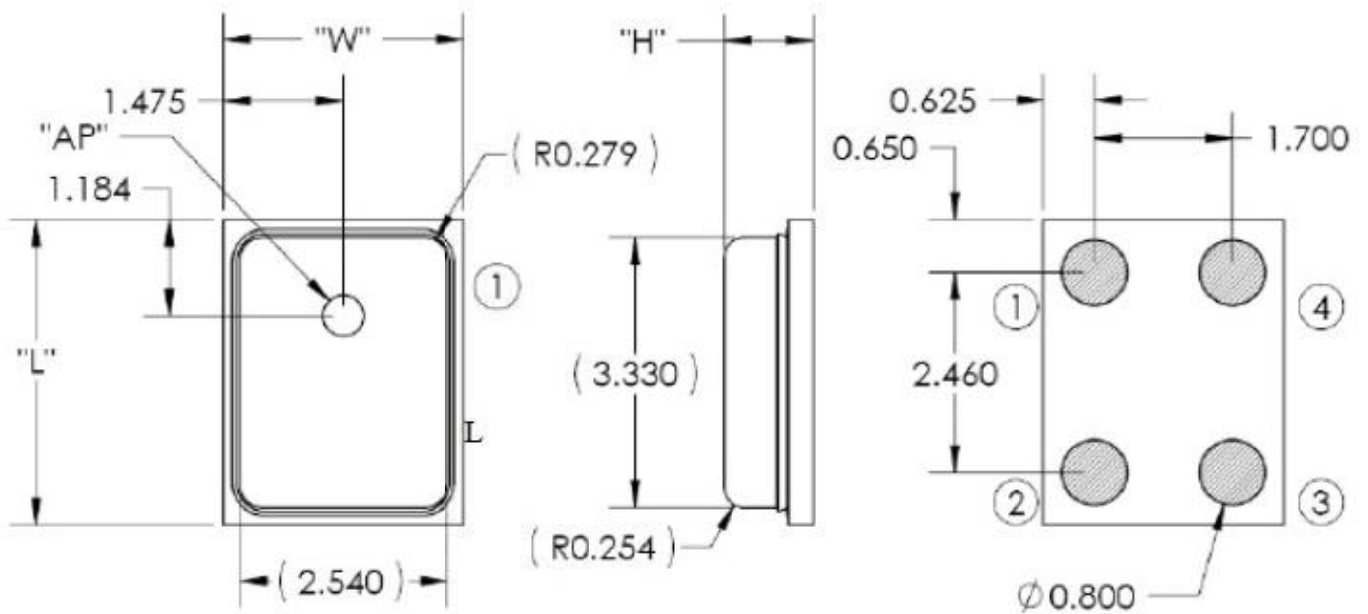

Items	Size	Tolerance	Unit
Length (L)	3.760	±0.100	mm
Width (W)	2.950	±0.100	mm
Height (H)	1.100	±0.100	mm
Acoustic port (AP)	Ø0.500	±0.100	mm

Recommending customer layout patterns

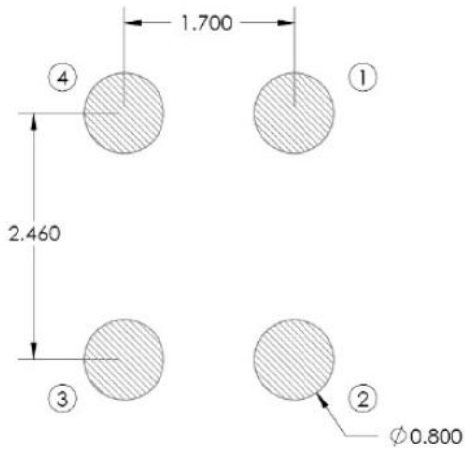

(Unit: mm)

Reflow chart

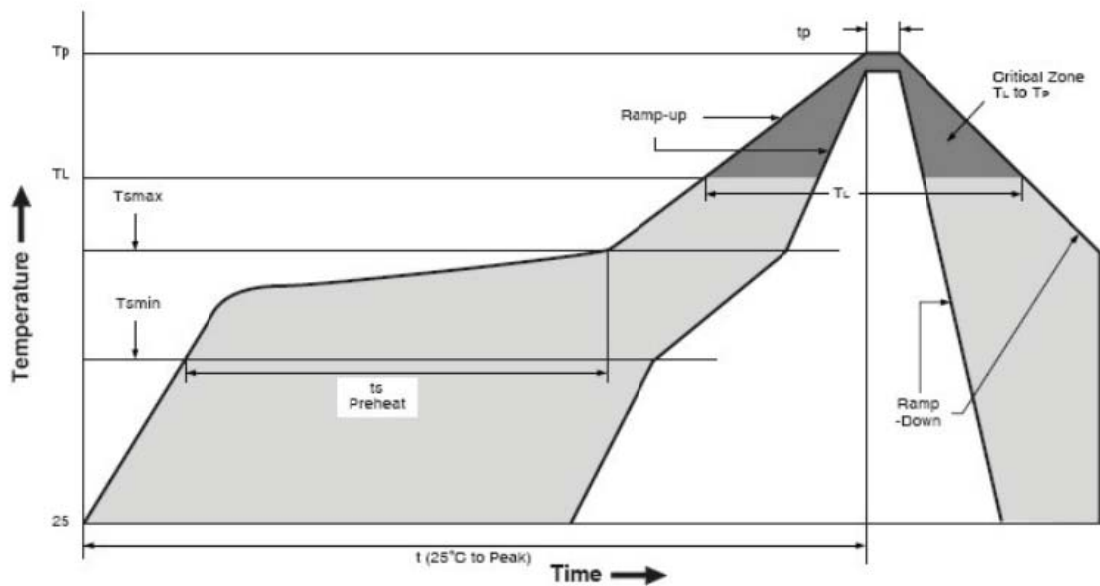

Stage	Max. Temperature range	Duration
Preheating	150°C-200°C	60-180sec
Welding	217°C	60-150sec
Peak temperature	260°C	20-40sec